

Article properties

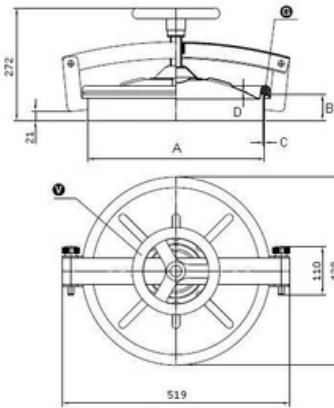

Article	9402.222E Round Inspection Cover 222/E Cover
Description	opening outwards Material: 1.4307 (304L) Pressure range: +0,1 bar Outside Neck diameter: Ø404mm Tolerance ISO2768 cL: ±2.0mm Welding Neck height: 100mm Welding Neck thickness: 3,0mm Cover thickness: 1,2mm 1x Plastic Handwheel MEC/200 EPDM gasket (FDA) G/AE200 Finish Neck: Grinded/Pickled Finish Cover: Electropolished 222/E (Neck 100x3) 304
Name	220E
Type	DN200
DN	404
A	100
B	3
C	1,2
D	0,1 bar
E	

Round Inspection Cover 222/E Cover opening outwards Material: 1.4307 (304L) Pressure range: +0,1 bar Outside Neck diameter: Ø404mm Tolerance ISO2768 cL: ±2.0mm Welding Neck height: 100mm Welding Neck thickness: 3,0mm Cover thickness: 1,2mm 1x Plastic Handwheel MEC/200 EPDM gasket (FDA) G/AE200 Finish Neck: Grinded/Pickled Finish Cover: Electropolished